

## REMOVAL AND INSTALLATION

### Clutch Disc and Pressure Plate — 4.0L

#### Special Tool(s)

 <p>ST1926-A</p>	<p>Clutch Aligner 308-020 (T74P-7137-K)</p>
---	---

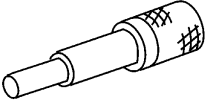
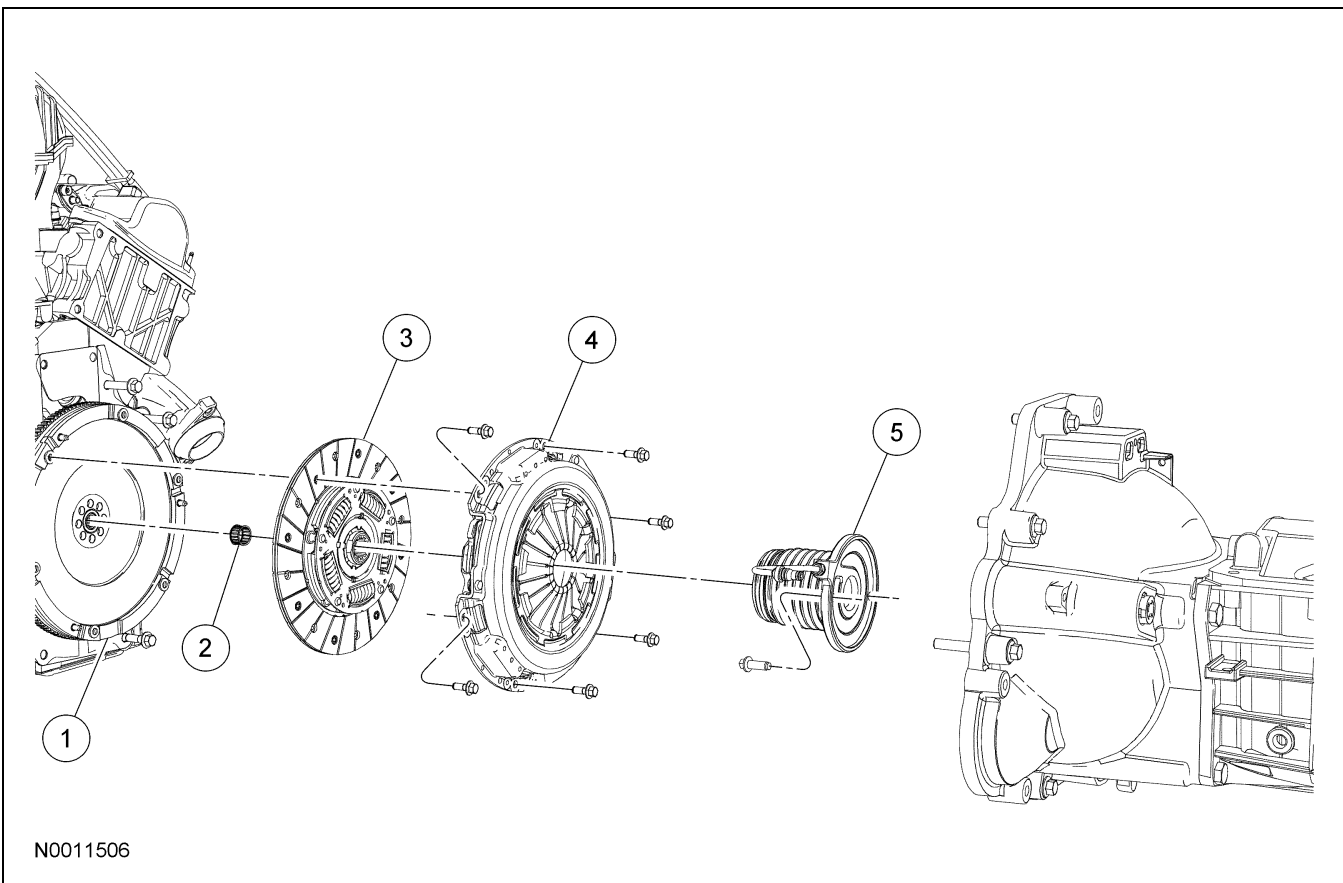

Item	Part Number	Description
1	6375	Flywheel
2	7600	Pilot bearing
3	7550	Clutch disc
4	7563	Pressure plate
5	7A508	Clutch release bearing/slave cylinder

#### Removal

1. Remove the transmission. For additional information, refer to Section 308-03A.

**REMOVAL AND INSTALLATION (Continued)**

2.  **CAUTION:** Loosen the bolts evenly to prevent clutch pressure plate damage.

**NOTE:** If the parts are to be reused, index-mark the pressure plate to the flywheel.

Remove the 6 pressure plate bolts, the pressure plate and the clutch disc. Discard the pressure plate bolts.

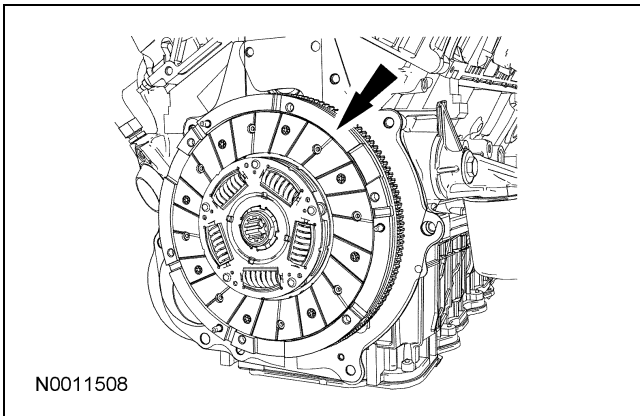
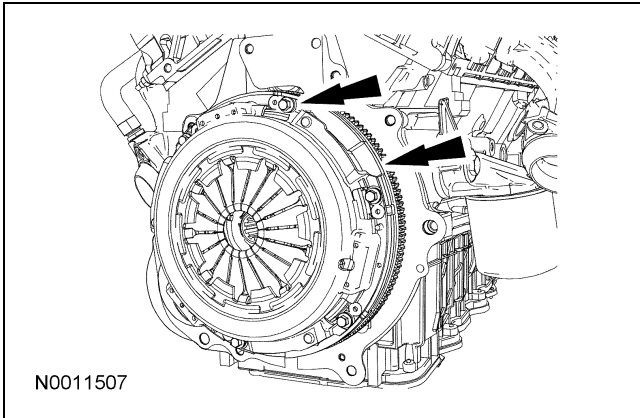
**Installation**

**NOTE:** If installing the original pressure plate, align it using the index marks made during removal.

**NOTE:** Clean the clutch pressure plate and flywheel with a commercial alcohol-based solvent so surfaces are free from oil film. Do not use cleaners with a petroleum base. Do not immerse the clutch pressure plate in the solvent.

**NOTE:** Always install new pressure plate bolts.

- Using the special tool, position the clutch disc on the flywheel, then install the pressure plate and new pressure plate bolts.
  - Tighten the bolts in a star pattern.
  - Remove the special tool.
  - Tighten to 35 Nm (26 lb-ft).

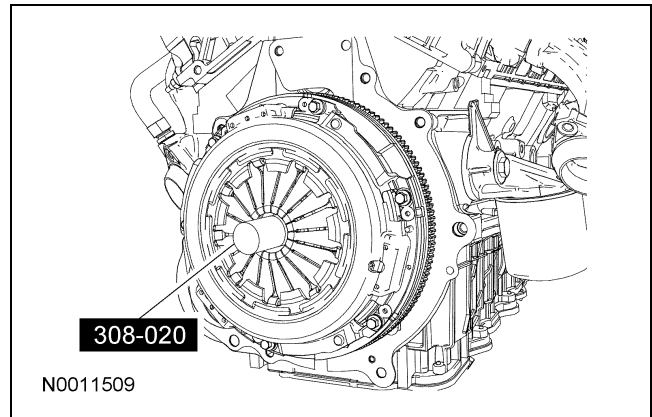

- NOTE:** Before securing the transmission to the engine, connect the clutch hydraulic line to the slave cylinder.

Install the transmission. For additional information, refer to Section 308-03A.

- Bleed the clutch hydraulic system. For additional information, refer to Section 308-00.